



ISO Registered Company

MODEL BR

BACK PRESSURE REGULATOR



MODEL BR

OVERVIEW

The Model BR is a general service, self-contained, back pressure regulator. Unit controls inlet pressures up to 120 psig (8.3 Barg) in multiple spring ranges. Model BR can be utilized for the majority of industrial pressure relief applications.

FEATURES

- Versatile:** Globe or Angular porting configuration. Two body materials with twenty nine trim materials to select from.
- Tight Shutoff:** Composition seats of V-TFE, NBR, and Neoprene available. Also available with metal seat. Class IV and VI Shutoff.
- Capacity:** Handles mid-range flow rates on a line size basis.
- Flow-to-Close Plug:** Incorporates the typical relief regulator internal design.
- Incorporated Cylinder:** Serves to make the unit convertible to angular design.
- Overpressure Travel Stop:** In the event of upstream over-pressurization, diaphragm over-travel is restricted by mechanical stops.

APPLICATIONS

Used in all types of fluids, including cryogenic liquids, sour gas, industrial gases, chemicals, as well as the common industrial fluids - water, oil, steam and compressed air.



LINE SIZES AVAILABLE

3/8" (DN10), 1/2" (DN15), 3/4" (DN20), 1" (DN25), 1-1/2" (DN40), 2" (DN50)



END CONNECTIONS

NPT, RAISED FACED FLANGED, BSPT, BSPP, EXTENDED NIPPLES



COMMON APPLICATIONS

CRYOGENIC LIQUIDS, SOUR GAS, INDUSTRIAL GASES, CHEMICALS, WATER, OIL, STEAM, COMPRESSED AIR



DESIGN PRESSURE

INLET PRESSURE:
2-120 psig (0.14-8.3 Barg)

STANDARD/GENERAL SPECIFICATIONS

Body Sizes: 3/8", 1/2", 3/4", 1" 1-1/2" & 2"
(DN10,15, 20, 25, 40 & 50).

Inlet Pressure Ranges: Standard: 2-120 psig (.14-8.3 Barg);
in four range springs. See Tables 1 and 2.

End Connections: Standard: NPT.
Opt-34: 150# (PN20) or 300# (PN50) RF flanges.
Opt-31: BSPT -Tapered thread female,
Opt-31P: BSPP-Parallel thread female.
Opt-32: Extended Nipples.

Trim Designs: Metal seated or composition seated, brass or SST materials. Metal or composition diaphragms. See Tables 3 and 4.

Body/Spring Chamber Material Combinations: CS/CS, SST/SST, SST/CS,
All spring chambers furnished with 1/8" (DN6) tapped vent hole. See Table 2 for material specifications.

Capacities: Up to 14.5 Cv See Tables 6 through 8.

Gaskets: Standard: TFE / Silicate
(NOTE: Composition diaphragms do not use a diaphragm gasket.)

Inlet Containment Pressure:

Body Material	Max Pressure	
	psig	(Barg)
LCC, SST	740	51.0

Temperatures: -20° to +400°F (-29° to +204° C)
Limited by body/spring chamber and trim material combinations.
See Tables 1, 3 and 4.
"CS" Mat'l - Steel - ASTM A352 Gr.
LCC - Minimum temperature -50 °F (-46 °C).

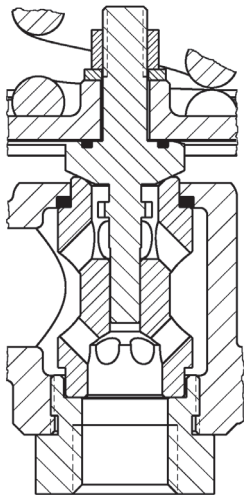

Figure 1: Metal Seat Design

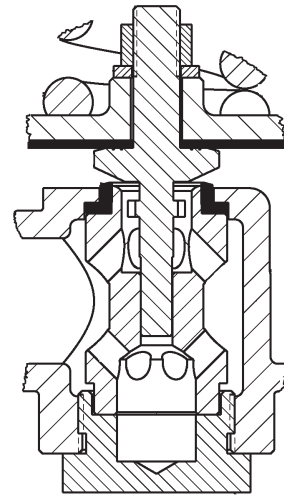

Figure 2: Composition Seat Design

Range Springs: Standard: Epoxy coated steel.
SST: -325 F to +400 F for
Cryogenic Construction

Painting: Standard: All non-corrosion resistant portions to be painted with corrosion resistant epoxy paint per Cashco Spec #S-1606.

Flange Bolting: Standard: Zinc plated, heat treated steel.
SST: -325 F to +400 F
Cryogenic Construction: SST

OPTION SPECIFICATIONS

Option -3: HANDWHEEL & LOCKING LEVER.
Utilize when P₁ pressure setting changes are frequent.

Option -36: SSTCRYOGENICCONSTRUCTION.
SST/SST body/spring chamber materials. NPT or flanged end connections. S1, and S36 trim selections only. SST flange bolting and range spring; remaining parts of brass or bronze materials. TFE-silicate gaskets. Drilled condensate drain hole near adjusting screw. Cleaned and packaged for oxygen service per Cashco cleaning specification #S-1134. Applicable temperature range -325° to +150° F (-198° to +66° C). **NOTE:** Design requires that spring chamber be mounted pointing downwards in a horizontal pipe.

Option -25P: PLASTIC RAIN PROOF BUG VENT.

Option -25S: SST RAIN PROOF BUG VENT.

Option -34: FLANGED END CONNECTIONS.
14" Face to Face Dimension.
CS or SST body materials only.
Flange and pipe nipple materials of same general chemistry as body material. Available in 150# RF or 300# RF flanges only. Not available 3/8" (DN10) body size. Not available 1-1/2" (DN40) with angle style.
NOTES:

1. The body P vs.T ratings of Table 1 are the limiting variables for flanged end connections, unless further restricted by ASME B16.5.

Option -40: CS NACE CONSTRUCTION.
Internal wetted portions meet NACE standard MR0175, when exterior of the regulator is not directly exposed to a sour gas environment, buried, insulated or otherwise denied direct atmospheric exposure. CS/CS body/spring chamber material with S40 and S40T only trim. (Alternate LCC body/spring chamber material with S40, S40B, S40C and S40T only trim.) Available all sizes, except 3/8" flanged (DN10). Opt-30 & -32 require post-weld stress relieving by heat treating.

Option -31: BSPT END CONNECTIONS. British Standard Tapered Pipe threads per ISO 7/1; used as an alternate to NPT ends. Not available 3/8" (DN10) body size.

Option -31P: BSPP END CONNECTIONS. British Standard Parallel Pipe threads per ISO 7/1; used as an alternate to NPT ends. Not available 3/8" (DN10) body size.

Option -32: EXTENDED NIPPLES. Schedule 80 plain end extension nipples available for carbon steel or 316 SST bodies. Nipples of same basic material as body. **NOTE:** Used where welded connections are required and in lieu of socket weld ends. Not available in 1-1/2" (DN 40) body size.

Option -40SST: SST NACE CONSTRUCTION. Same as Opt-40, except uses SST/SST body/spring chamber construction.

Option -55: SPECIAL CLEANING. SST body material ONLY. Cleaning per Cashco Spec. #S-1134 for oxygen service. **NOTE:** Design Pressure Rating shall not exceed 375 psig (25.8 Barg) when process medium is oxygen.

Option -56: SPECIAL CLEANING. All body materials. Cleaning per Cashco Spec. #S-1542. Cleaning identical to that of Opt-55, but not labeled for application in oxygen service. Not intended for oxygen service.

Option -85: INLET GAUGE CONNECTION BODY TAP. 1/8" (DN6) NPT connection.

**TABLE 1
MAXIMUM ALLOWABLE PRESSURE vs. TEMPERATURE;
FOR PRESSURE CONTAINMENT OF
BODY / SPRING CHAMBER & BODY CAP ¹**

Pressure vs. temperature ratings in accordance with ASME B31.3.

NOTE: The below ratings may be further "derated" by limitations through the Pressure Equipment Directive (2014/68/EU)

Materials of Construction Description - Abbreviation Body/Spring Chamber/Body Cap	Temperature		Containment Pressure					
			NPT		150 RF		300 RF	
	°F	(°C)	psig	Barg	psig	Barg	psig	Barg
CS/CS/SST ¹	-20 to +100	(-29 to +37)	740	51.0	285	19.6	740	51.0
	+200	(+94)	740	51.0	260	17.9	680	46.9
	+250	(+121)	740	51.0	245	16.9	665	45.8
	+300	(+149)	740	51.0	230	15.8	655	45.1
	+400	(+205)	740	51.0	200	13.8	635	43.8
SST/CS/SST ¹ SST/SST/SST ¹	-20 to +100	(-29 to +37)	740	51.0	275	18.9	720	49.6
	+200	(+94)	740	51.0	235	16.2	620	42.7
	+250	(+121)	740	51.0	225	15.5	590	40.6
	+300	(+149)	740	51.0	215	14.8	560	38.6
	+400	(+205)	740	51.0	195	13.4	515	35.5
Option -36 CRYOGENIC CONSTRUCTION								
SST/SST/SST	-325 to + 150	-198 to +66	740	51.0	275	18.9	720	49.6

¹ Minimum temperature -50°F (-46°C) when selecting Trim S40B or S40C. SST Spring

**TABLE 2
MATERIAL SPECIFICATIONS OF
BODY, SPRING CHAMBER & BODY CAP**

Material	ASTM Specifications
BR - brass	B16 Alloy C83600.
CS - cast carbon steel	ASTM A352 Gr. LCC
SST - cast stainless steel	A351, Gr. CF8M (cast 316 SST)
	A479 UNS 31600/03

**TABLE 3
BRASS TRIM MATERIAL COMBINATIONS**

PART	BRASS TRIM #								
	METAL SEAT		COMPOSITION SEAT						
	B0 ¹	B1	B2 (Air/H ₂ O)	B3	B4	B5 ¹ (Oxygen)	BB (Fuel-Oils)	BJ	BK
Diaphragm	Phos Brz	302 SST	BC	BC	FKM	Phos Brz	NBR	FK	FKM
Cylinder	Brass	Brass	Brass	Brass	Brass	Brass	Brass	Brass	Brass
Piston	Brass	Brass	Brass	Brass	Brass	Brass	Brass	Brass	Brass
Seat Disc	None (Metal)	None (Metal)	NBR	PTFE	PTFE	PTFE	NBR	PTFE	FKM
Temperature Range	-20 to +200°F -29 to +94°C	-20 to +400°F -29 to +205°C	-20 to +200°F -29 to +94°C	-20 to +200°F -29 to +94°C	-20 to +300°F -29 to +149°C	-20 to +400°F -29 to +205°C	-20 to +250°F -29 to +121°C	-20 to +300°F -29 to +149°C	

¹ For cryogenic applications; B0 or B5 trim designations ONLY are allowed for -325° to +150°F (-198° to +66°C) range.

**TABLE 4(a)
STAINLESS STEEL TRIM MATERIAL COMBINATION – METAL SEAT**

PART	STAINLESS STEEL TRIM #						
	S0	S1 ¹	S2 (Steam)	S2N	SG	S40 (NACE)	S40B (NACE)
Diaphragm	TFE Coated 302 SST	302 SST	302 SST	BC	Gylon	BC	BC *
Cylinder	316 SST	316 SST	416 SST	416 SST	416 SST	316 SST	316SST
Piston	316 SST	316 SST	416 SST	416 SST	416 SST	316 SST	316SST
Seat Disc	None (Metal)	None (Metal)	None (Metal)	None (Metal)	None (Metal)	None (Metal)	None (Metal)
Temperature Range	-20 to +400°F -29 to +205°C			-20 to +200°F -29 to +94°C	-20 to +400°F -29 to +205°C	-20 to +200°F -29 to +94°C	-50 to +250°F -46 to +121°C

¹ For cryogenic applications; S1 trim designation is ONLY allowed for -325° to +150°F (-198° to +66°C) range.
* Special BC Material for Low Temperature.

**TABLE 4(b)
STAINLESS STEEL TRIM MATERIAL COMBINATION – COMPOSITION (SOFT) SEAT**

PART	STAINLESS STEEL TRIM #												
	S3	S4	S4N (Air/H ₂ O)	S6 (Hot Air/H ₂ O)	S7	S9	S36 ¹	S40T (NACE)	S40C (NACE)	SB	SJ	SK	SP
Diaphragm	BC	BC	BC	EPDM	FKM	TFE Coated 302 SST	302 SST	FKM	BC *	NBR	FK	FKM	BC *
Cylinder	316 SST	416 SST	416 SST	316 SST	316 SST	316 SST	316 SST	316 SST	316 SST	416 SST	316 SST	316 SST	316 SST
Piston	316 SST	416 SST	416 SST	316 SST	316 SST	316 SST	316 SST	316 SST	316 SST	416 SST	316 SST	316 SST	316 SST
Seat Disc	PTFE	PTFE	NBR	EPR	PTFE	PTFE	PTFE	PTFE	PTFE	NBR	PTFE	FKM	BC
Temp Range	-20 to +200°F -29 to +94°C		-20 to +300°F -29 to +149°C		-20 to +400°F -29 to +205°C		-20 to +400°F -29 to +205°C	-50 to +250°F -46 to +121°C	-20 to +250°F -29 to +121°C	-20 to +300°F -29 to +149°C		-40 to +250°F -40 to +121°C	

¹ For cryogenic applications; S36 trim designation is ONLY allowed for -325° to +150°F (-198° to +66°C) range.
* Special BC Material for Low Temperature.

ABBREVIATIONS
 NBR = Buna-N BC = Neoprene EPDM = Ethylene Propylene Diene EPR = Ethylene Propylene PTFE = Polytetrafluoroethylene
 FK = Fluorosilicone FKM = Fluorocarbon elastomer V-TFE = Virgin TFE Phos BRZ = Phosphor Bronze

**TABLE 5
APPLICATIONS**

FLUID	RECOMMENDED CONSTRUCTION	TRIM DESIGNATION #
Air or Inert Gases	Composition Seat and Diaphragm	B2, B3, B4, SB, S4N
	Metal Seat and Composition Diaphragm	S2N
	Metal Seat and Diaphragm	B0, B1
Oxygen	Composition Seat and Diaphragm	B4, BJ, S7, SJ
	Composition Seat and Metal Diaphragm	B5, S36
	Metal Seat and Diaphragm	S1
Chemicals	Metal Seat and Diaphragm	S1, S2, S0
	Metal Seat and Composition Diaphragm	S40
	Composition Seat and Diaphragm	SB, S3, S4, S4N, S6 or S40T
	TFE seat and Metal Diaphragm	S9
Sour Gas	Metal Seat and Composition Diaphragm	S40 (S40B *)
	Composition Seat and Diaphragm	S40T (S40C *), SP
Cryogenic Gas or Liquids	TFE Seat and Metal Diaphragm	S36
	Metal Seat and Diaphragm	S1
Fuel Oil	Composition Seat and Diaphragm	BB, B4, SB, S3, S4, or S4N
Hydrocarbon Gas or Liquids	Composition Seat and Diaphragm	BB, B3, B4, S3, S4, or S4N
Saturated Steam, Low Pressures - up to 50 psig (3.4 Barg)	Metal Seat and Diaphragm	S2, B0, or S1
	Metal Seat and Composition Diaphragm	SG
	Composition Seat and Diaphragm	S6
Saturated Steam, Pressures up to 100 psig (6.8 Barg) 50 psid (3.4 Barg)	Metal Seat and Diaphragm	S2, B0, B1 or S1
	Metal Seat and Composition Diaphragm	SG
Steam Pressures above 100 psig (6.9 Barg) Saturated or Superheated	Metal Seat and Diaphragm	S2 or S1
Water and Condensate Low Temperature: 32–180°F (0–83°C)	Composition Seat and Diaphragm	B2, B3, BB, SB, S3, S4, or S6, S4N
	Metal Seat and Composition Diaphragm	S2N
	Metal Seat and Diaphragm	S1, S2
Water and Condensate High Temperature: 180–300°F (83–149°C)	Metal Seat and Diaphragm	S1 or S2
* NACE Trims for use w/ LCC Body Material Temperature Range -50 to +400°F (-46 to +204°C).		

**TABLE 6
CV CAPACITY AT % BUILD**

Pressure Setpoint Psp psig	CV Capacity @ % Build 1/2" (DN15) Body			Range Spring
	10%	20%	30%	
5	0.25	0.89	1.40	2-10
10	0.43	1.73	2.54	
5	0.15	0.58	0.93	5-30
10	0.30	1.15	1.74	
15	0.44	1.62	2.41	
20	0.58	2.08	2.65	
25	0.73	2.48	2.75	
30	0.89	2.57	2.75	
25	0.25	0.95	1.47	25-60
40	0.39	1.46	2.19	
50	0.49	1.77	2.60	
60	0.58	2.06	2.75	
50	0.20	0.78	1.22	50-120
70	0.28	1.07	1.65	
90	0.36	1.35	2.04	
110	0.44	1.61	2.39	
120	0.48	1.73	2.55	

Pressure Setpoint Psp psig	CV Capacity @ % Build 1" (DN25) Body			Range Spring
	10%	20%	30%	
5	0.91	1.65	3.01	2-10
10	1.64	2.98	4.09	
5	0.27	0.49	0.96	5-30
10	0.52	0.95	1.82	
15	0.76	1.39	2.58	
20	0.99	1.80	3.24	
25	1.20	2.19	3.80	
30	1.40	2.55	4.20	
25	0.69	1.26	2.36	25-60
40	1.06	1.93	3.43	
50	1.29	2.34	4.00	
60	1.50	2.72	4.20	
50	0.49	0.90	1.73	50-120
70	0.68	1.24	2.33	
90	0.86	1.56	2.86	
110	1.03	1.87	3.34	
120	1.11	2.02	3.56	

Pressure Setpoint Psp psig	CV Capacity @ % Build 1-1/2" (DN40) Body			Range Spring
	10%	20%	30%	
5	1.33	2.42	4.05	2-10
10	2.47	4.49	6.98	
5	0.33	0.60	1.05	5-30
10	0.65	1.19	2.04	
15	0.96	1.74	2.97	
20	1.25	2.28	3.84	
25	1.55	2.81	4.64	
30	1.83	3.32	5.39	
25	0.82	1.49	2.56	25-60
40	1.28	2.33	3.90	
50	1.57	2.86	4.72	
60	1.86	3.38	5.47	
50	0.81	1.47	2.52	50-120
70	1.11	2.02	3.42	
90	1.40	2.55	4.26	
110	1.69	3.07	5.04	
120	1.83	3.32	5.40	

Pressure Setpoint Psp psig	CV Capacity @ % Build 2" (DN50) Body			Range Spring
	10%	20%	30%	
5	1.25	2.28	4.34	2-10
10	2.36	4.30	7.81	
5	0.36	0.66	1.32	5-30
10	0.72	1.31	2.56	
15	1.06	1.93	3.74	
20	1.40	2.54	4.85	
25	1.72	3.12	5.88	
30	2.03	3.70	6.85	
25	1.03	1.87	3.64	25-60
40	1.61	2.92	5.53	
50	1.97	3.59	6.68	
60	2.33	4.24	7.73	
50	1.09	1.99	3.87	50-120
70	1.51	2.75	5.23	
90	1.91	3.48	6.48	
110	2.30	4.18	7.63	
120	2.49	4.52	8.16	

TABLE 7
AIR CAPACITY IN SCFH
S.G. = 1.0 T = 60°F $F_L = 0.945$
(Outlet Pressure is Atmosphere)

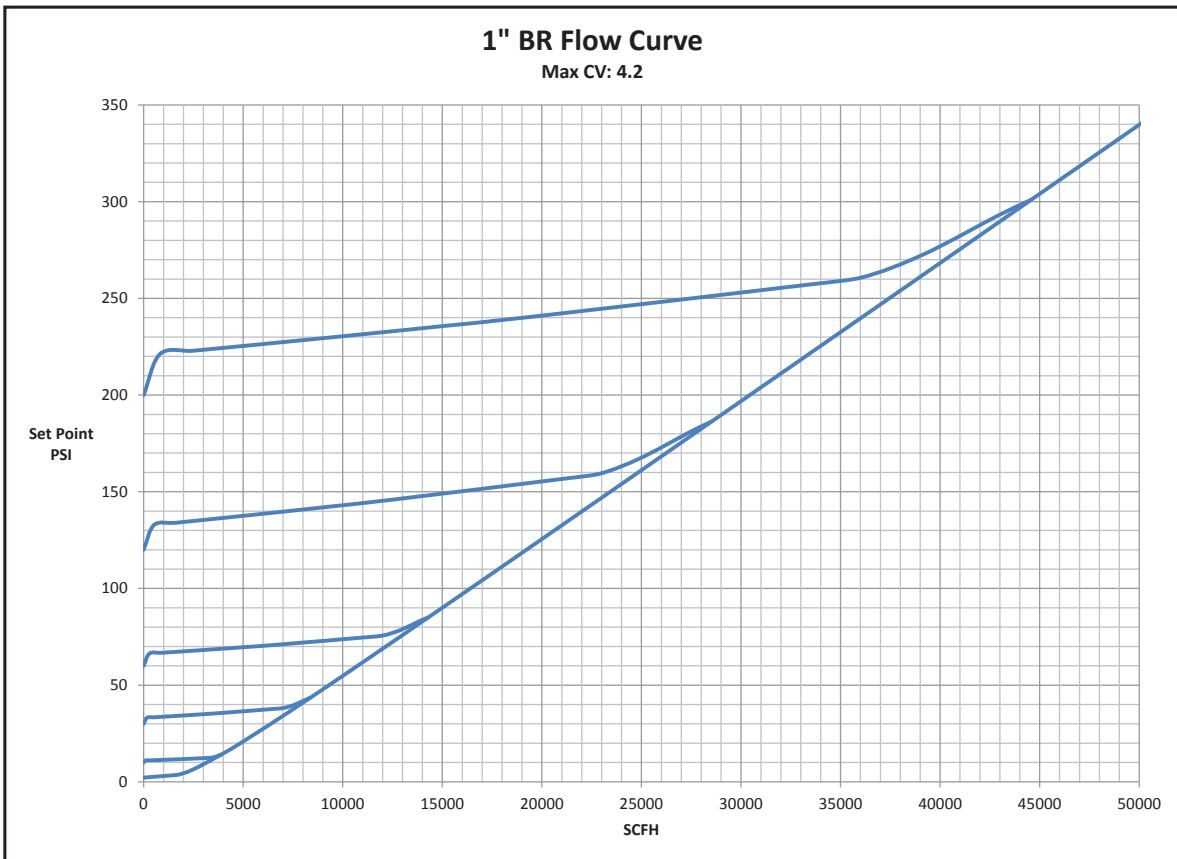
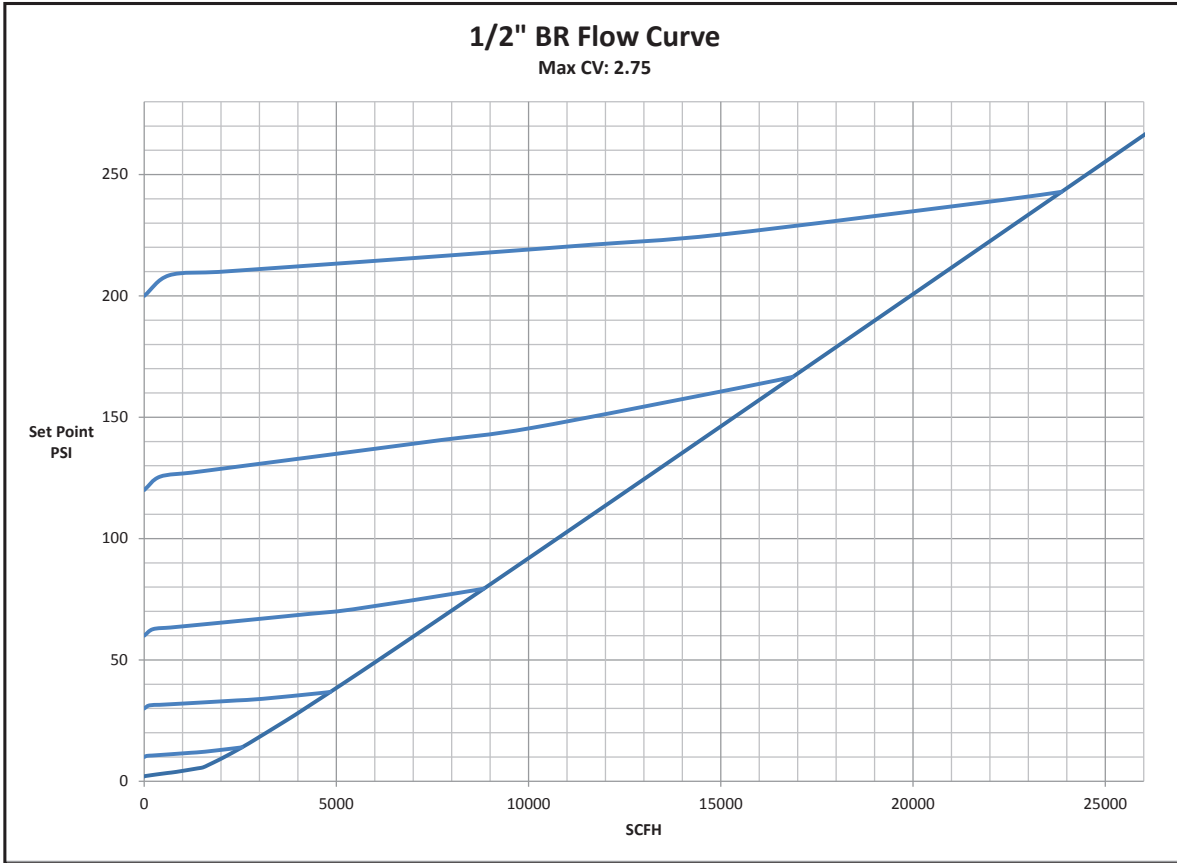

TABLE 7
AIR CAPACITY IN SCFH
 S.G. = 1.0 T = 60°F $F_L = 0.945$
 (Outlet Pressure is Atmosphere)

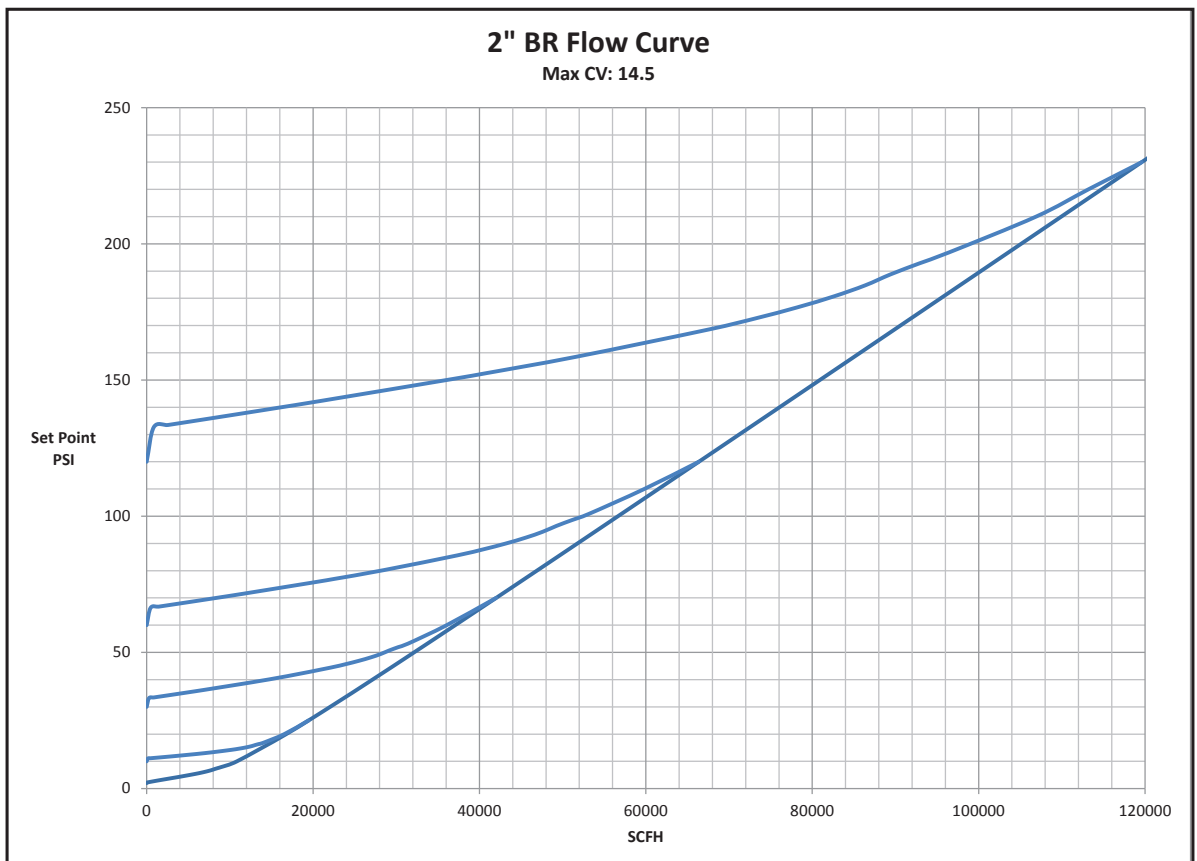
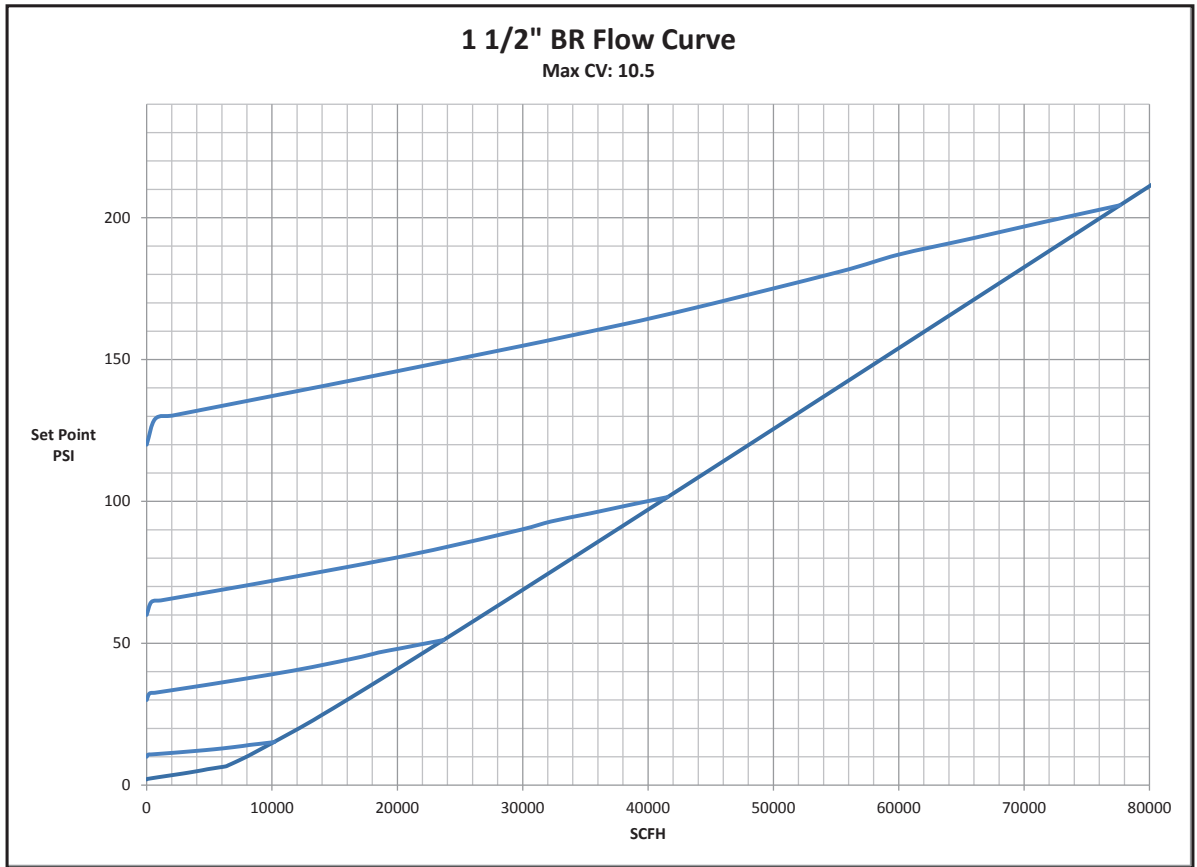

TABLE 8
WATER CAPACITY IN GPM
 S.G. = 1.0 T = 60°F $F_L = 0.945$
 (Outlet Pressure is Atmosphere)

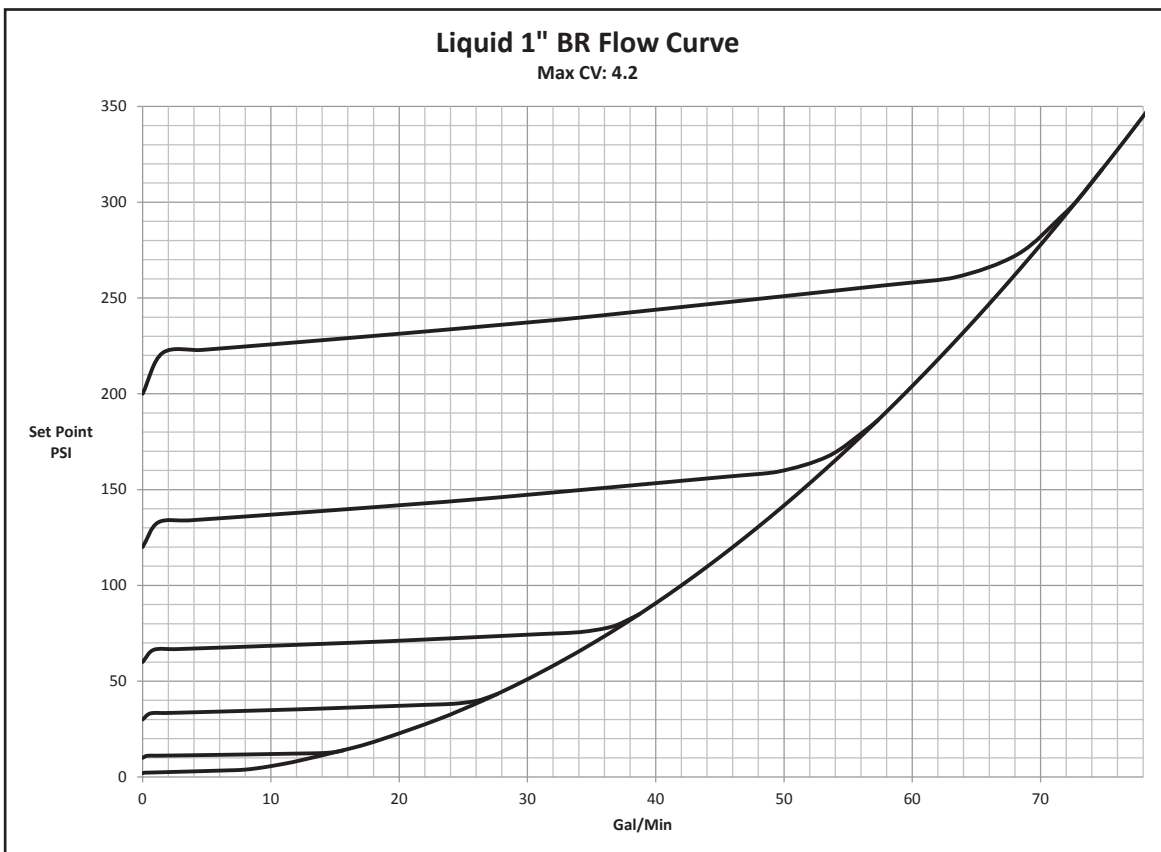
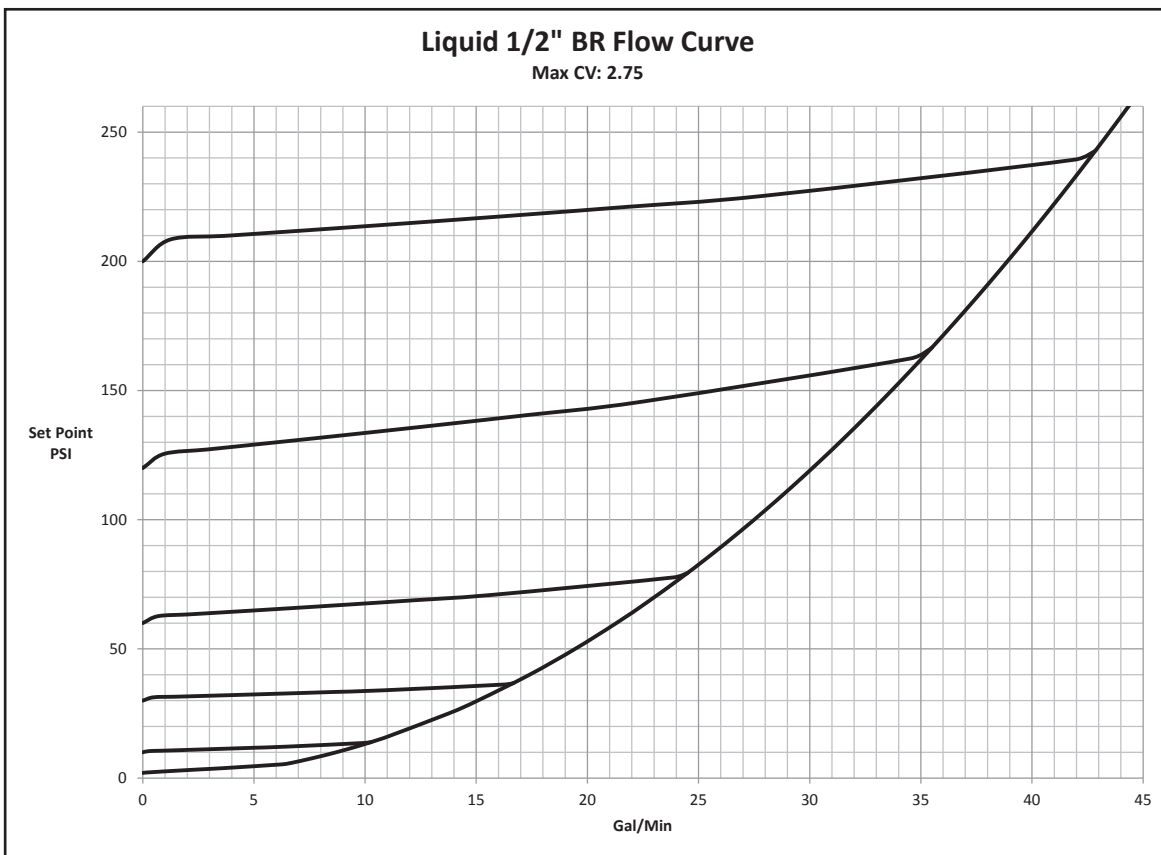
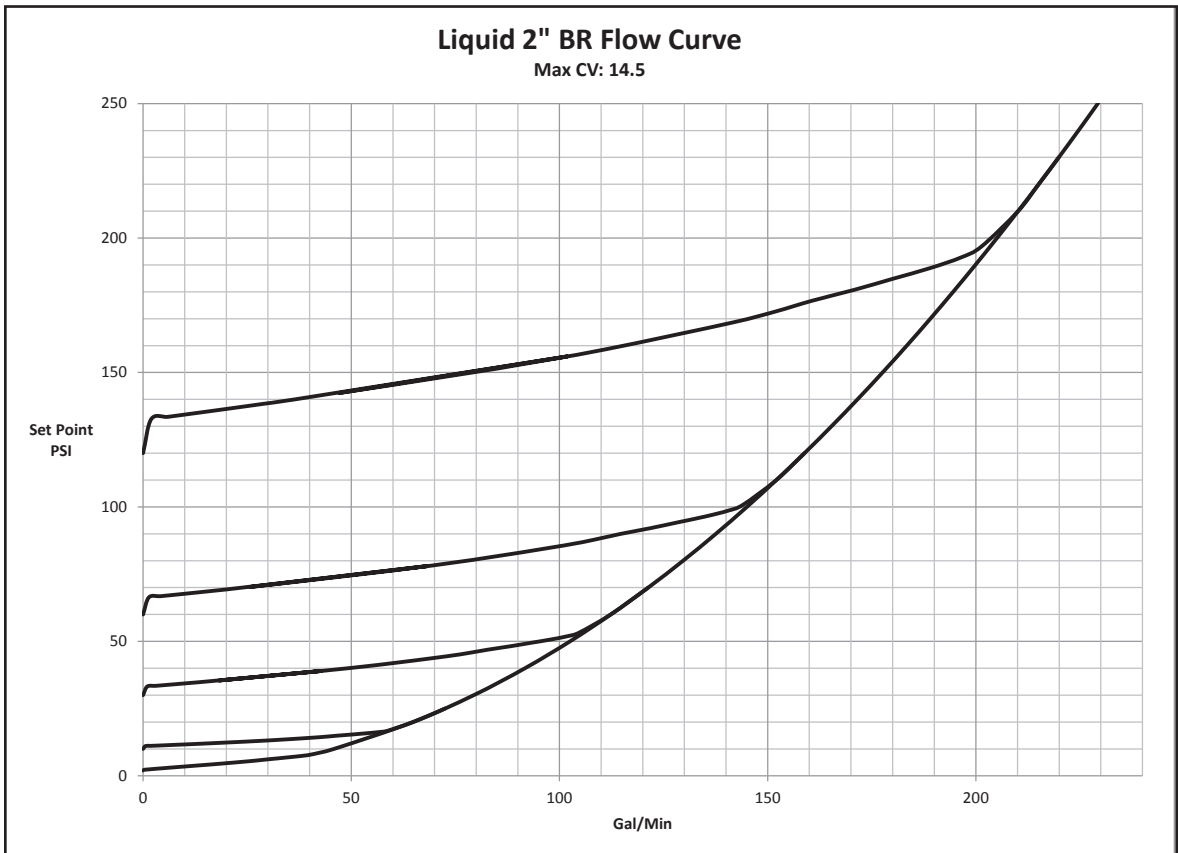
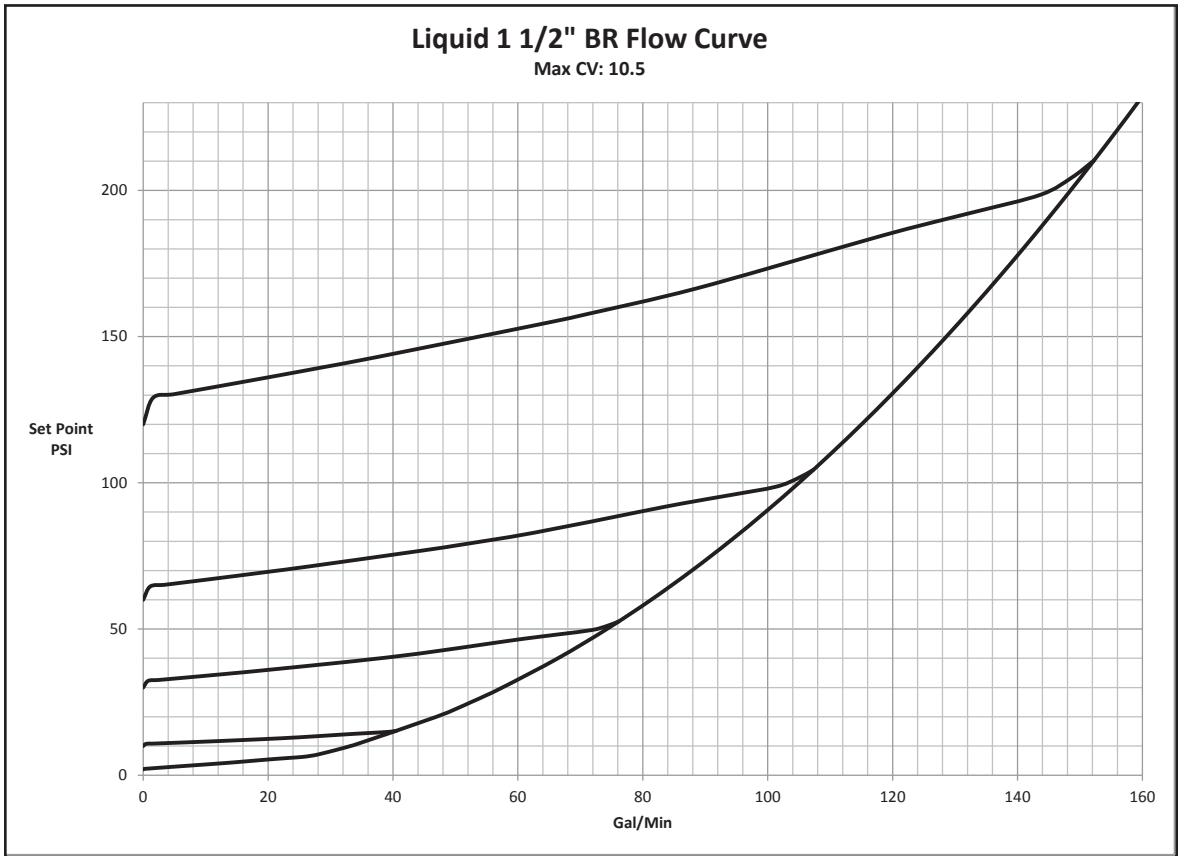
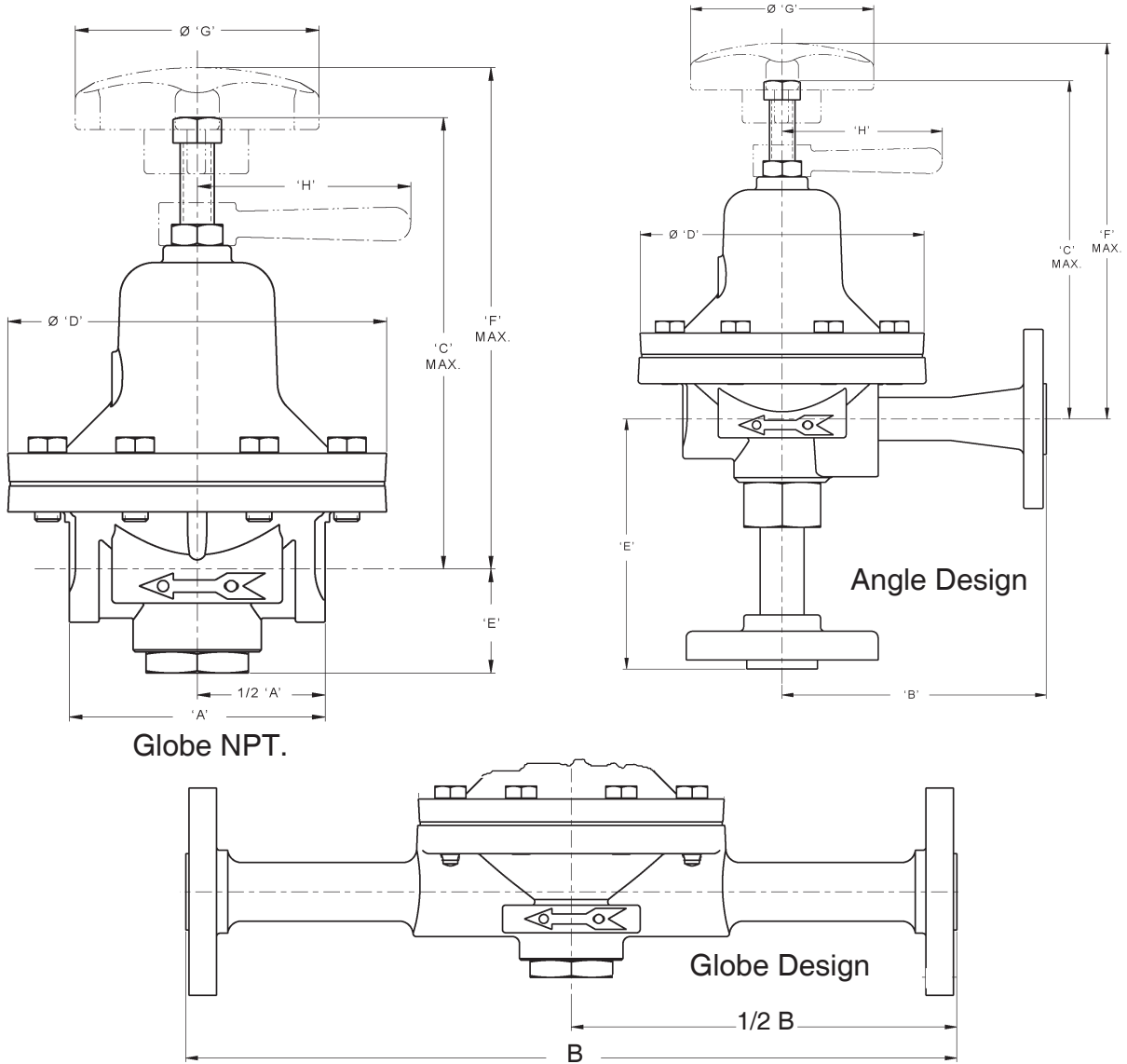

TABLE 8
WATER CAPACITY IN GPM
 S.G. = 1.0 T = 60°F $F_L = 0.945$
 (Outlet Pressure is Atmosphere)



DIMENSIONS & WEIGHTS



Size Inch	Dimensions - English (In.)															Shipping Weight lbs. ⁵
	Globe A	Angle 1/2 A	Globe B ¹	Angle B ²	Globe B ³	Angle B ³	Max C	D	Globe E ⁴	Angle E ⁴	Angle E ²	Angle E ³	F	G	H	
3/8	3.75	1.87	NA	NA	NA	NA	6.31 *	5.63	1.63	1.81	NA	NA	7.69 *	4.0	3.25	10
1/2	3.75	1.87	14.0	5.16	16.32	8.16	6.31 *	5.63	1.63	1.81	4.88	7.88	7.69 *	4.0	3.25	10
3/4 & 1	4.82	2.41	14.0	6.19	17.0	8.50	7.25 **	6.75	1.44	2.56	5.56	7.75	8.63 **	4.0	3.25	15
1-1/2	6.35	3.17	14.0	NA	NA	NA	7.63	8.13	2.25	3.31	NA	NA	8.13	4.0	3.25	25
2	7.16	3.58	14.0	7.19	18.0	9.0	9.44	9.63	2.38	3.75	6.38	8.19	9.63	4.0	3.25	47
¹ Globe Design 150# & 300# Integral Flanged ² Angle Design 150# & 300# Flanged, Opt-30 ³ Extended Nipples, Opt-32 ⁴ NPT conn. ⁵ Weight does not include flanged options.																

Size (DN)	Dimensions - Metric (mm.)															Shipping Weight Kgs. ⁵
	Globe A	Angle 1/2 A	Globe B ¹	Angle B ²	Globe B ³	Angle B ³	Max C	D	Globe E ⁴	Angle E ⁴	Angle E ²	Angle E ³	F	G	H	
(10)	95	47	NA	NA	NA	NA	160	143	41	46	NA	NA	195	102	83	4.5
(15)	95	47	356	131	415	207	160	143	41	46	124	200	195	102	83	4.5
(20 & 25)	122	61	356	157	432	216	184	171	37	65	141	197	219	102	83	6.8
(40)	161	80	356	NA	NA	NA	194	207	57	84	NA	NA	206	102	83	12
(50)	182	91	356	183	457	229	240	245	60	95	162	208	245	102	83	21.3
¹ Globe Design 150# & 300# Integral Flanged ² Angle Design 150# & 300# Flanged, Opt-30 ³ Extended Nipples, Opt-32 ⁴ NPT conn. ⁵ Weight does not include flanged options.																

Cryogenic OPT-36 SST Body Mat'l

An "X" in POS 12 followed by a 5-digit control number overrides remaining selections.

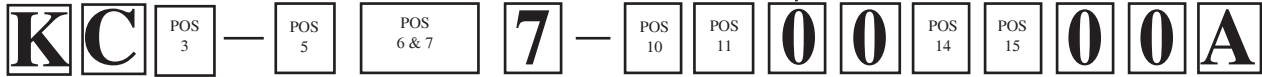

POSITION 3 - SIZES / Configuration			
Size		Globe CODE	Angle CODE
in	(DN)		
3/8"	(10)	3	H
1/2"	(15)	4	J
3/4"	(20)	5	K
1"	(25)	6	L
1-1/2" *	(40)	8	N
2"	(50)	9	P

* Angle config. only available with threaded conn.

POSITION 5 - BODY & SPRING CHAMBER MATERIAL TEMPERATURE RANGE	
Body/ Sp. Ch.	-325° to +400° F
	CODE
SST/SST	A

NOTE: See TB pg. 4 Table 1 for Design Pressure / Temperature Ratings.

POSITION 6 & 7 - TRIM DESIGNATION NUMBERS	
Stainless Steel Trim	
Desig.	CODE
S1 ^	S1
S36 ^	36

POSITION 10 - END CONNECTIONS	
Description	CODE
NPT - Screwed	1
-31 Opt. - BSPT - Screwed Tapered Pipe Thread	B
-31P Opt. - BSPP - Screwed Parallel Pipe Thread	P
-34 Opt. - 150 LB RF Flgs. (14" F to F Dimension)* **	V
-34 Opt. - 300 LB RF Flgs. (14" F to F Dimension) * **	W

* CS/SST Bodies Only.
Nipples & flanges of same material as body.
** Not available in 1-1/2" size with Angle Config.
*** Not available in 1-1/2" size.

POSITION 11 - RANGE SPRINGS		
SST Range Spring		CODE
psig	(Barg)	
2-10	(.14-0.68)	1
5-30	(.34-2.1)	2
25-60	(1.7-4.1)	3
50-120	(3.4-8.3)	4

POSITION 14 - SPRING CHAMBER OPTIONS		
Description	Option	CODE
No Option	---	0
SST Rain-proof Bug Vent (includes Opt-25).	-25S	H

POSITION 15 - BODY OPTIONS		
Description	Option	CODE
No Option	---	0
1/8" (DN6) NPT Tap on inlet for gauge connection.	-85	T

*** For information on ATEX see pages 9 & 10 on the IOM.**

The contents of this publication are presented for informational purposes only, and while every effort has been made to ensure their accuracy, they are not to be construed as warranties or guarantees, express or implied, regarding the products or services described herein or their use or applicability. We reserve the right to modify or improve the designs or specifications of such product at any time without notice. Cashco, Inc. does not assume responsibility for the selection, use or maintenance of any product. Responsibility for proper selection, use and maintenance of any Cashco, Inc. product remains solely with the purchaser.

MODEL BR PRODUCT CODE 02/07/20

An "X" in POS 12 followed by a 5-digit control number overrides remaining selections.

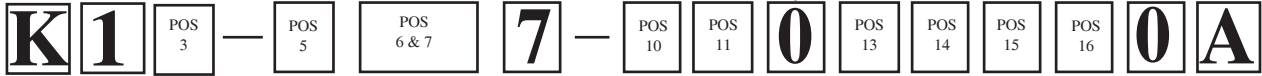

POSITION 3 - SIZES / Configuration			
Size		Globe CODE	Angle CODE
in	(DN)		
3/8"	(10)	3	H
1/2"	(15)	4	J
3/4"	(20)	5	K
1"	(25)	6	L
1-1/2"	(40)	8	N
2"	(50)	9	P

* Angle config. only available with threaded conn.

POSITION 5 - BODY & SPRING CHAMBER MATERIAL TEMPERATURE RANGE	
Body/ Sp. Ch.	CODE
CS/CS	5
SST/CS	9
SST/SST	A

NOTE: See TB pg. 4 Table 1 for Design Pressure / Temperature Ratings.

POSITION 6 & 7 - TRIM DESIGNATION NUMBERS			
Brass Trim		Stainless Steel Trim	
Desig.	CODE	Desig.	CODE
B0	B0	S0	S0
B1	B1	S1 ^	S1
B2	B2	S2	S2
B3	B3	S2N	SN
B4 ^	B4	S3	S3
B5 ^	B5	S4	S4
BB	BB	S4N	SD
BJ ^	BJ	S6	S6
BK	BK	S7 ^	S7
		S9	S9
		S36 ^	36
		S40	40
		S40T	4T
		S40B	4B
		S40C	4C
		SB	SB
		SG	SG
		SJ ^	SJ
		SK	SK
		SP	SP

^ Trim Designation Nos. usable for oxygen service.

POSITION 10 - END CONNECTIONS	
Description	CODE
NPT - Screwed	1
-34 Opt. - 150 LB RF Flgs. (14" F to F Dimension) * **	V
-34 Opt. - 300 LB RF Flgs (14" F to F Dimension) * **	W
-31 Opt. - BSPT - Screwed Tapered Pipe Thread	B
-31P Opt. - BSPP - Screwed Parallel Pipe Thread	P
-32 Opt. - SCH. 80 PE Ext. Nipples * ***	E

* CS/SST Bodies Only, Nipples & flanges of same material as body.
 ** Not available in 1-1/2" size with Angle Config.
 *** Not available in 1-1/2" size.

POSITION 13 - FEATURE OPTIONS		
Description	Option	CODE
No Option	---	0
Handwheel & Locking Lever.	-3	3

POSITION 14 - SPRING CHAMBER OPTIONS		
Description	Option	CODE
No Option	---	0
Plastic Rain-proof Bug Vent	-25P	P
SST Rain-proof Bug Vent (includes Opt-25).	-25S	H

POSITION 15 - BODY OPTIONS		
Description	Option	CODE
No Option	---	0
1/8" (DN6) NPT Tap on inlet for gauge connection.	-85	T

POSITION 16 - CERTIFICATE OPTIONS		
Description	Option	CODE
No Option	---	0
NACE Const: CS/CS/XX Per MR0175, S40, S40B, S40C, S40T Trims.	-40	J
NACE Const: SST/SST/XX Per MR0175, S40, S40B, S40C, S40T Trims.	-40SST	K
Special Cleaning: Per Cashco Spec #S-1134. W/ properly selected mat'ls. Suitable for Oxygen Service SST body material.	-55	M
Special Cleaning: Per Cashco Spec #S-1542.	-56	N

POSITION 11 - RANGE SPRINGS		
Ranges		CODE
psig	(Barg)	
2-10	(.14-0.68)	1
5-30	(.34-2.1)	2
25-60	(1.7-4.1)	3
50-120	(3.4-8.3)	4

*** For information on ATEX see pages 9 & 10 on the IOM.**