



MODEL 1100 SANITARY VENT

The Model 1100 is a stainless steel sanitary vent designed to operate at multiple set points as a breather valve to avoid vacuum or over pressurization inside a tank or piping system. This unit comes with a true sanitary blanketing connection, and is designed so that it can be used with our sanitary blanketing valve; VCI model 1088.



Model 1100 shown with Model 1088

FEATURES

CONSTRUCTION

Housing: 316L Stainless Steel.

Flange base is Sanitary Quick-Clamp; can be supplied with all gaskets and clamps necessary for installation.

Stainless steel weather screen prevents debris from entering the tank.

Available Sizes: 2", 3", 4", and 6"

Seal Material: FKM (Viton);
Materials are FDA Certified USP Class VI.

APPLICATION

Used in pharmaceutical industry in production of many health care products for both human and animal consumption. Widely applied for processed food production — candy, beverages, nutritional supplements and artificial sweeteners. May also be used in cosmetics production and specialty chemicals.

Easy Inspection, Installation and Maintenance:

Ingenious design and industrial construction permits easy, convenient handling for inspection, installation and maintenance. No adjustment is required during reassembly after cleaning or maintenance to establish set point. Main vent complies with sanitary standards for self-draining and machine finish requirements.

Maintains Accurate Settings:

Controlled design for an accurate, repeatable set point. Minimum setting down to 0.43 psi for pressure and 0.04 psi for vacuum. Maximum setting upwards to 3.42 psi for pressure and 0.381 psi for vacuum. See Table 1 and Table 2.

Shutoff:

An extremely tight shut off with a leakage rate better than the industry standard of less than 1 SCFH at 90% of set point is verified for both pressure and vacuum which prevents waste of blanketing gases. All vents are 100% tested to meet Cashco's seat leakage requirements.

FEATURES

Sanitary Construction - SST Construction - Interior of body surface Electro Polished to 16 micro-inch Ra finish. Unit is cleaned to Cashco Spec. #S-1576. Comply with FDA 21 CFR 177 2600 & USP Class VI material classification.

SPECIFICATIONS

Body		Body Size and Material:	2", 3", 4", and 6" (DN50, DN80, DN100, and DN150) sizes. 316L stainless steel.
Connections:	Sanitary Quick-Clamp		

Range Springs:

Table 1 Pressure Range:		
Size	Min Setpoint (psi)	Max Setpoint (psi)
2"	0.49	3.42
3"	0.44	3.31
4"	0.43	2.67
6"	0.44	2.19

Table 2 Vacuum Range:		
Size	Min Setpoint (psi)	Max Setpoint (psi)
2"	0.081	0.385
3"	0.068	0.358
4"	0.069	0.319
6"	0.087	0.397

DIMENSIONS & WEIGHTS

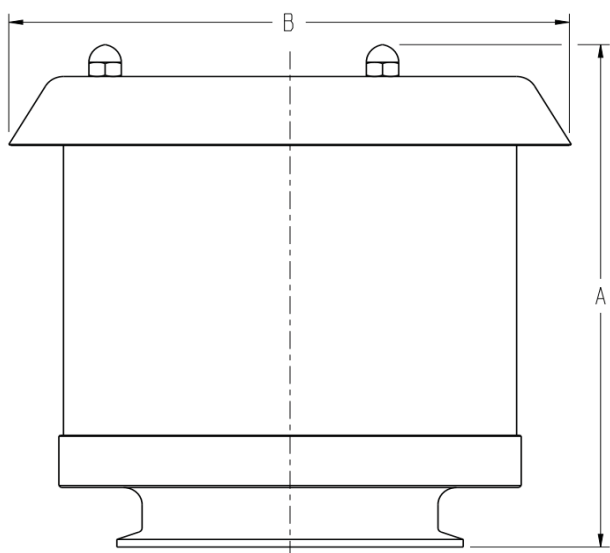

**Standard Without 3/4"
Connection**

SIZE	DIMENSIONS - inches (mm)		Weights - lbs. (kg)
	A	B	
2"	6.02 (152.9)	5.03 (127.8)	4.16 (1.89)
3"	6.31 (160.3)	6.89 (175.0)	7.46 (3.38)
4"	7.39 (187.7)	7.60 (193.0)	9.85 (4.47)
6"	9.64 (244.9)	11.43 (290.3)	24.58 (11.15)

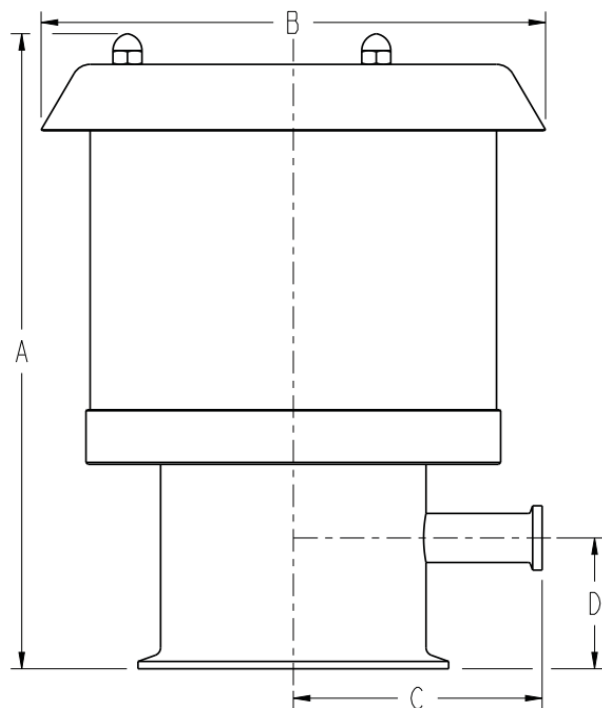

**With 3/4" Blanket
Connection**

SIZE	DIMENSIONS - inches (mm)				Weights - lbs. (kg)
	A	B	C	D	
2"	7.58 (192.5)	5.03 (127.8)	2.75 (69.9)	1.50 (38.1)	4.16 (1.89)
3"	9.21 (233.9)	6.31 (160.3)	3.25 (82.6)	2.00 (50.8)	8.14 (3.69)
4"	9.71 (246.6)	7.60 (193.0)	3.75 (95.3)	2.00 (50.8)	10.87 (4.93)
6"	13.96 (354.6)	11.43 (290.3)	4.75 (120.7)	3.00 (76.2)	27.83 (12.62)

The contents of this publication are presented for informational purposes only, and while every effort has been made to ensure their accuracy, they are not to be construed as warranties or guarantees, express or implied, regarding the products or services described herein or their use or applicability. We reserve the right to modify or improve the designs or specifications of such product at any time without notice. Cashco, Inc. does not assume responsibility for the selection, use or maintenance of any product. Responsibility for proper selection, use and maintenance of any Cashco, Inc. product remains solely with the purchaser.

1100 PRODUCT CODE 09/25/17

Last 6 Characters reserved for SPQ drawing numbers assigned by Cashco Inc.
(Format as - # # # # # #)

S **V** **T** POS 4 POS 5 **B** **0** **1** **0** **0** POS 11 **K** **0** **0** **0** **0** **0**

POSITION 4 - SIZE	
INCH ASME	CODE
2" - DN50	2
3" - DN80	3
4" - DN100	4
6" - DN150	6

POSITION 5 - BODY/ TRIM/ PALLET MATERIAL		
MATERIAL	With 3/4" Blanket Connection	Without 3/4" Blanket Connection
	CODE	
316 SST	B	D

POSITION 11 - OPTIONS	
DESCRIPTION	CODE
None	0
Supplied with Clamps and FKM (Viton) Gaskets	1

Cashco, Inc.
P.O. Box 6
Ellsworth, KS 67439-0006
PH (785) 472-4461
Fax. # (785) 472-3539
www.cashco.com
email: sales@cashco.com
Printed in U.S.A. 1100-TB

Cashco GmbH
Handwerkerstrasse 15
15366 Hoppegarten, Germany
PH +49 3342 30968 0
Fax. No. +49 3342 30968 29
www.cashco.com
email: germany@cashco.com

Cashco do Brasil, Ltda.
Al.Venus, 340
Indaiatuba - Sao Paulo, Brazil
PH +55 11 99677 7177
Fax. No.
www.cashco.com
email: brazil@cashco.com