

Magnetically operated level switches

Selection table
Equipment for Magnetic Level Gauges type 710

Product group **740**

Type **-**

Sheet: 1/1

Revision: 6

Date:

05/05

Table Mechanical Data

Type	for Level Gauge 710.						Housing							Ingr. prot. EN 60529	Temperature			Vibration tolerance																	
	098/104	100/100.3/104/200/300	104.3	110/120	102/103/106	130/140/150/160	Material			Dimensions					Ambient	ins.pipe		0.5 g	3 g	15 g															
740.0060	●	●	●	●	●	●	Alu	Makrolon	Pocan	SS	20x100	28x25	45x50	65x50	65x65	80x82	95x165	IP 54	IP 65	IP 67	-30 ... +70(90) °C *)	-40 ... +100 °C	-40 ... +120 °C	-65 ... +125 °C	-60 ... +200 °C	150/350 °C **)	150/400 °C **)	150/500 °C **)	0.5 g	3 g	15 g				
740.0062	●	●	●	●	●	●	●	●	●	●	●	●	●	●	●	●	●	●	●	●	●	●	●	●	●	●	●	●	●	●	●	●	●		
740.0064	●	●	●	●	●	●	●	●	●	●	●	●	●	●	●	●	●	●	●	●	●	●	●	●	●	●	●	●	●	●	●	●	●		
740.0065	●	●	●	●	●	●	●	●	●	●	●	●	●	●	●	●	●	●	●	●	●	●	●	●	●	●	●	●	●	●	●	●	●	●	
740.0066 1)	●	●	●	●	●	●	●	●	●	●	●	●	●	●	●	●	●	●	●	●	●	●	●	●	●	●	●	●	●	●	●	●	●	●	
740.0200	●	●	●	●	●	●	●	●	●	●	●	●	●	●	●	●	●	●	●	●	●	●	●	●	●	●	●	●	●	●	●	●	●	●	●

Table Electrical Data, Ex-Classification

Type	Ex protection			Switch element	Switch							Switch cycles	Electr. connect.																								
	Ex d	Ex i	Ex m		Voltage			Current			Rupturing capacity			Silicon cable	PVC cable	Screw terminals																					
740.0060	●	●	●	Reed switch, SPST	Triac	Prox. sw., DIN 19234	8.2 V= (DIN 19234)	230V~/230 V=	230V~/200 V=	250V~/200 V=	24 V~ bis 230 V~	0.4 mA/2.5 mA	10 mA=	1 A~/0.5 A=	2 A~	2 A~/2 A=	24 mA~ bis 2.5 A~	<< 1 W	1 W	30 VA/30 W	100 VA/40 W	100 VA	550 VA	> 10 ⁵	> 10 ⁶	> 10 ⁷	Silicon cable	PVC cable	Screw terminals								
740.0062	●	●	●	Rotary switch, SPDT	●	●	●	●	●	●	●	●	●	●	●	●	●	●	●	●	●	●	●	●	●	●	●	●	●	●	●	●	●	●			
740.0064	●	●	●	●	●	●	●	●	●	●	●	●	●	●	●	●	●	●	●	●	●	●	●	●	●	●	●	●	●	●	●	●	●	●	●		
740.0065	●	●	●	●	●	●	●	●	●	●	●	●	●	●	●	●	●	●	●	●	●	●	●	●	●	●	●	●	●	●	●	●	●	●	●	●	
740.0066	●	●	●	●	●	●	●	●	●	●	●	●	●	●	●	●	●	●	●	●	●	●	●	●	●	●	●	●	●	●	●	●	●	●	●	●	
740.0200	●	●	●	●	●	●	●	●	●	●	●	●	●	●	●	●	●	●	●	●	●	●	●	●	●	●	●	●	●	●	●	●	●	●	●	●	●

Remarks

- to use without restrictions
- ⊙ to use with precautions, if the switch is part of an intrinsically safe circuit, e. g. DIN 19234 (Namur)

*) Makrolon-/Alu-housing

**) without insulate/with insulate

1) no insulation between switches and pipe possible

Accessories: Transmitter feed circuit

Subject to alterations

PHÖNiX

Messtechnik GmbH
Salzschlirfer Straße 13
D-60386 Frankfurt/M.
Tel. +49/69/41 67 42 -20
Fax +49/69/41 67 42 -29
sales@phoenix-mt.com
www.phoenix-mt.com

PHÖNiX

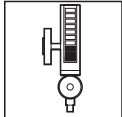

Magnetic Power switch

Universal bistable magnetically operated switch
Semiconductor relay controlled by Reed switch
Switch direction reversible

Product group **740**

Type **0060**

Sheet: 1/2

Revision: 3

Date:

9/07



Field of Application

This switch is for signalling level limits with magnetic level gauges.
The switch element Reed has a very low mass and so can sustain very high shock and vibration stress.
It can be used for power switching and small signal switching, you only have to use the appropriate screw terminals.

General Data

Hysteresis ca. [mm]:

Gauge-Type	on basic pipe	on heating jacket
710.104/2XX	6	15
710.100	10	20
710.110...160	15	25

Fitting position:

Cable gland downwards

Ingress protection:

IP65

Material housing:

Alu/Makrolon

Manner of fastening:

with strap retainers

(Accessories s. page 2)

Measures/weight:

Makr.: 82x80x55/0,15 kg

Alu: 75x80x57/0,3 kg

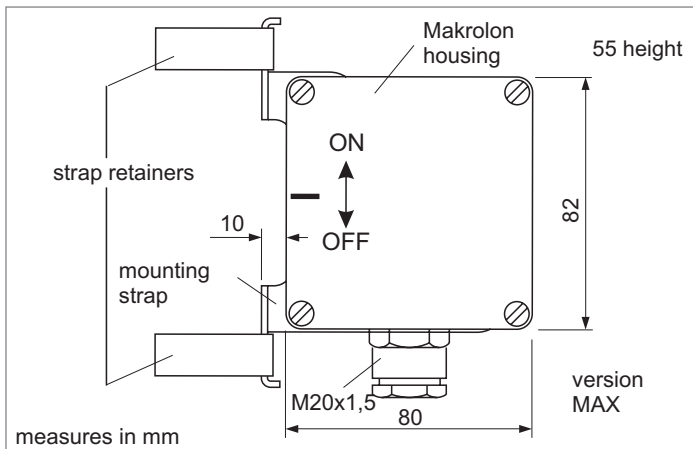

measures in mm

Design Data

Operating mode		max. temperature of pipe	max. temp. of housing
Power switch (Solid state Triac-relay)	Makr.	150 °C *) at amb.Temp.85 °C	70 °C
	Alu	400 °C *) at amb.Temp.55 °C	90 °C
Small signal switch (Reed)	Makr.	150 °C *) at amb.Temp.120 °C	120 °C
	Alu	500 °C *) at amb.Temp.70 °C	120 °C

Connection diagram

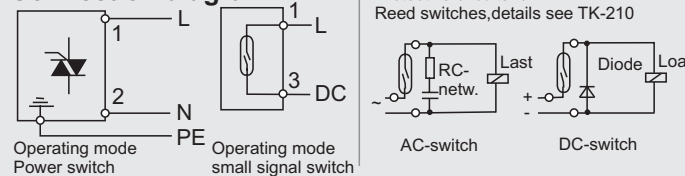

Operating mode Power switch

Operating mode small signal switch

Protective circuits for Reed switches, details see TK-210

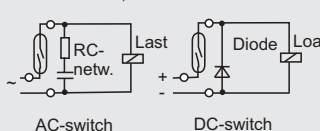

*) Insulate between housing and pipe above 150 °C in pipe

Switch cycles:

10⁶ - 10⁷

Shock:

15 g

Vibrations:

10 g

Subject to alterations

Ordering no.

740.0060 - X???????

Housing

A=Alu

M=Makrolon

?=Code not in use

PHÖNIX

Messtechnik GmbH
Salzschlirfer Straße 13
D-60386 Frankfurt/M.
Tel. +49/69/41 67 42 -20
Fax +49/69/41 67 42 -29
sales@phoenix-mt.com
www.phoenix-mt.com

PHÖNIX

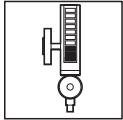

Magnetic Power switch

Application hints

Product group **740**

Type **0060**

Sheet: 2/2

Revision: 3

Date:

9/07

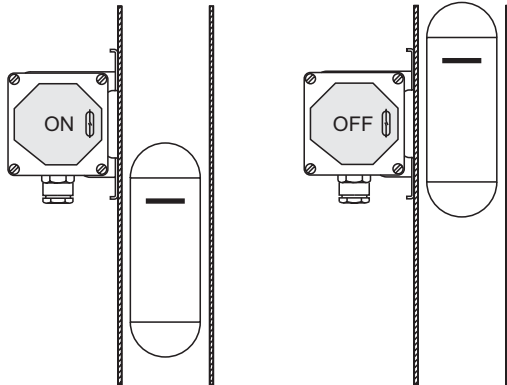

Switch configured as MIN
switched on, if float is below

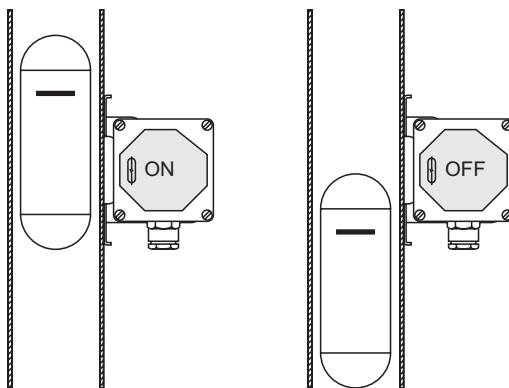

Switch configured as MAX, pc-board and strap retainer reversed
switched on, if float is above

Circuit diagram

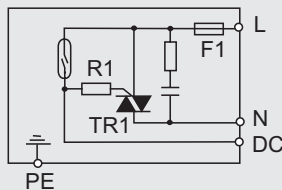

Electrical Data

Cable gland: M20x1,5
Screw terminals: 2,5 mm²

Power switch (Solid state relay with Triac)

Operating voltage nominal for 90 % power: 24 V~ to 230 V~
Operating voltage limit: 250 V~
Load current nominal for 90 % power / 230 V~: 24 mA~ to 2,5 A~
OFF-current (230 V~): 6 mA~
max. power limit $P_{n \max}$: 550 VA
max. power limit $P_{n \min}$: s. Diagram below

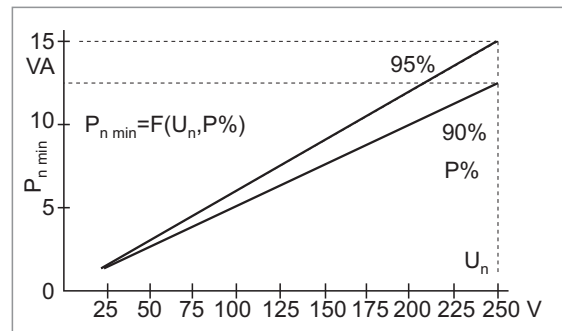

Small signal switch (Reed)

Operating voltage limit: 200 V~ / 230 V~
Operating current limit: 0,5 A
Rupturing capacity $U \times I_{\max}$: 5 W

The switch is not suitable for the ex area also with the exclusive use as 'small signal switch'.

Subject to alterations

Ordering no. for accessories

Accessories	Ordering No.
All fixing elements made of 1.4571	5945005556
Mounting strap	171538
Strap retainers for 710.104/2XX	171546
Strap retainers for 710.100/103	171553
Strap retainers for 710.110/120/106/130/100.3	

PHÖNIX

Messtechnik GmbH
Salzschlirfer Straße 13
D-60386 Frankfurt/M.
Tel. +49/69/41 67 42 -20
Fax +49/69/41 67 42 - 29
sales@phoenix-mt.com
www.phoenix-mt.com

PHÖNIX

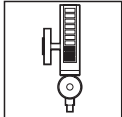

Magnetically operated switch Ex m

Bistable change-over switch with patented switch element
Switch contacts magnetically operated
Pipe clamp integrated

Product group **740**

Type **0062**

Sheet: 1/1 Revision: 4

Date: 08/04

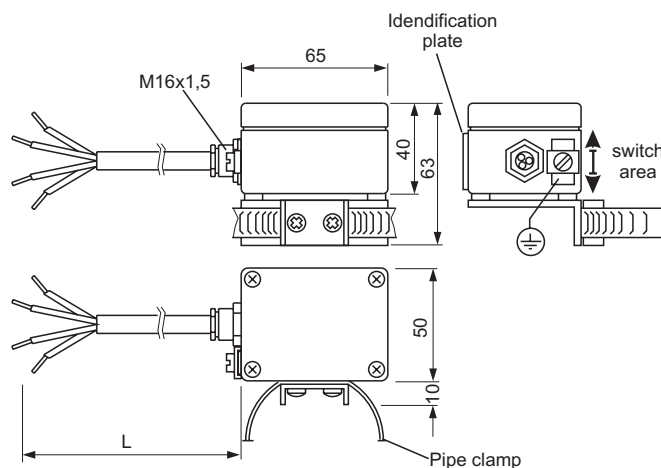

measures in mm

Connection diagram

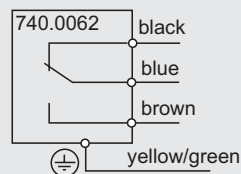

Range of application

This SPDT switch is for signalling level limits of magnetically operated liquid level gauges. It works with contact types which need not be protected by special means and so may be operated with higher loads. The switch can be used for Ex-Zone 2 and Ex Zone 1.

General Data

Hysteresis: 18 mm (with Type 710.100)
Material housing: Aluminium
Fixing device for magnetic gauge type:
A: 710.100.0/104/2XX.0 pipe clamp Ø40-60 mm
B: 710.102/103/106...140 pipe clamp Ø60-80 mm

Design Data

Temperature ambient: -45 to +125 °C
Temperature housing: -65 to +125 °C
Temperature in gauge pipe: up to 400 °C *)
Switch cycles: > 10⁵
*) Insulate between switch and gauge pipe above 150 °C in pipe
Ex-protection: EEx m II T4, T5, T6
Ambient temperature for temperature class:
T4: -45 °C to +125 °C
T5: -45 °C to +95 °C
T6: -45 °C to +80 °C

Function

MAX (Float above): black - blue closed
MIN (Float below): brown - blue closed

Electrical Data

Switch over bistable: SPDT
Switch voltage: 200 V =/250 V~
Switch current: 2 A~/~
max. power limit: 40 W/100 VA
Contact material: AgCd / Au5µ
Transit time: < 50 ms
Connection: 3 m silicone cable (resistantly approximately nick) 4 x 0,75 mm²
Ingress protection acc. to EN 60529: IP 67

Certificates

EC-Type-Examination Certificate: ZELM 02 ATEX 0079

Subject to alterations

Ordering no.

740.0062 - X - XXX - cable length L in m

A	710.100.0/104/2XX.0	for magnetic gauge type
B	710.102/103/106...140	

PHÖNIX

Messtechnik GmbH
Salzschlirfer Straße 13
D-60386 Frankfurt/M.
Tel. +49/69/41 67 42 -20
Fax +49/69/41 67 42 -29
sales@phoenix-mt.com
www.phoenix-mt.com

PHÖNIX

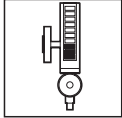

Magnetically operated SPDT switch

Bistable change-over switch with patented switch element
Switch contacts magnetically operated

Productgroup **740**

Type **0064**

Sheet: 1/1

Revision: 9

Date:

03/05



Type
740.0064



Execution with
heat guard plate

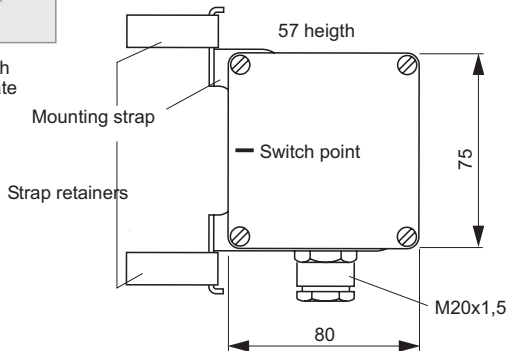

Measures in mm

Range of application

This SPDT switch is for signalling level limits of magnetically operated liquid level gauges. It works with contact types which need not be protected by special means and so may be operated with higher loads. Ex-Zone 2 in general and Ex Zone 1 with intrinsically safe circuits is allowed, because only passive elements are built into a swaged-tight housing.

General Data

Hysteresis: 18 mm (with Type 710.100)
Material housing: Aluminium
Fixing device for magnetic gauge type (accessory):
710.100.0/104/098/2XX.0 strap retainers Ø40-60 mm
710.102/103/106...140 strap retainers Ø60-80 mm

Design Data

Switch cycles: $>10^5$

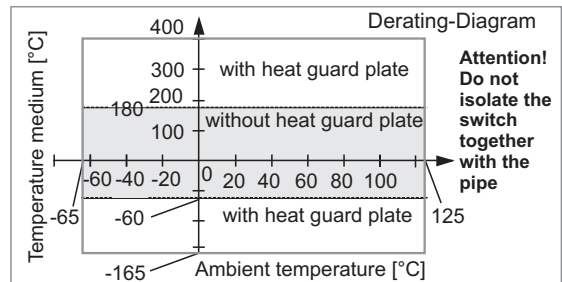

Function

MAX (Float oabove): black (1) - blue (2) closed
MIN (Float below): brown (3) - blue (2) closed

Electrical Data

Switch over bistable: SPDT
Switch voltage: 200 V =/250 V~
Switch current: 2 A=/
max. power limit: 40 W/100 VA
Contact material: AgCd / Au5µ
Transit time: < 50 ms
Connection: 3 m or 5 m cable, 4 x 0,75 mm² or screw terminals 3 x 2,5 mm²
Cable gland: M20x1,5
Ingress protection acc. to EN 60529: IP67
Optional resistors R_p, R_s for wire interruption and short circuit control or as Namur circuit.

Subject to alterations

Connection Diagram

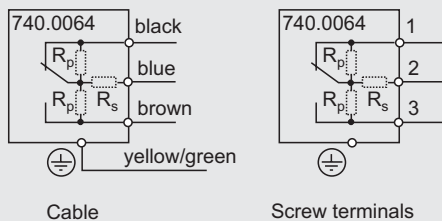

Ordering no.

740.0064 - XXXXX

Contact material	Normal	C	I	inverse	Magnetic field direction
	Gold	G	N	normal	
Housing material	Aluminum	A	K	screw terminals	Electrical connection
			3	3 m cable	
			5	5 m cable	
Resistor circuit	without	O	H	Harting plug	Temp. in the pipe
	Namur 1k/10k	N	0	up to +250 °C	
	wire interr. 10k/10k	D	H	250...+450 °C	

PHÖNIX

Messtechnik GmbH
Salzschlierfer Straße 13
D-60386 Frankfurt/M.
Tel. +49/69/41 67 42 -20
Fax +49/69/41 67 42 -29
sales@phoenix-mt.com
www.phoenix-mt.com

PHÖNIX

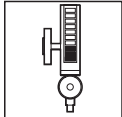

Magnetically controlled Limit Switch

Bistable magnetic switch
Reed contact
Switch direction reversible

Product group **740**

Type **0065**

Sheet: 1/1

Revision: 8

Date:

1/07



Picture:
Type 740.0065
IP 67

Field of Application

This switch is for signalling level limits with magnetic level gauges.
The switch element Reed has a very low mass and so can sustain very high shock and vibration stress.
By using only passive elements (Reed contact, resistors) the switch can operate in hazardous area zone 2 and as part of an intrinsic safe circuit also in zone 1.

General Data

Hysteresis ca. [mm]:

Gauge Type	on basic pipe	on heating jacket
710.104/2XX	6	15
710.100	10	20
710.110...160	15	25

Fitting position: cable gland downwards
Manner of fastening: with strap retainers
Ingress protection: IP67
Material housing: Alu
Measures/weight: Alu: 75x80x57/0,3 kg

Design Data

housing	max. temperature of pipe	temperature of housing
Alu	500 °C *) at amb. temp. 70 °C	-40 ... 120 °C

*) Insulate between housing and pipe above 260 °C in pipe

Switch cycles: > 10⁶
Shock: 15 g
Vibration: 10 g

Electrical Data

Switch voltage: 200 V =/230 V~
Switch current: 0,5 A
max. power limit: 5 W
Connection: screw terminals, M20x1,5

Accessories

Strap retainers for 710.104/2XX: 171538
Strap retainers for 710.100/103: 171546
Strap retainers for 710.110-130/106/100.3: 171553

subject to alterations

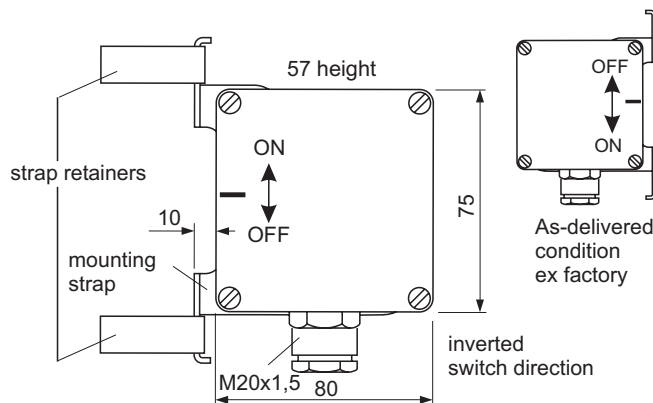

measures in mm

Connection diagram

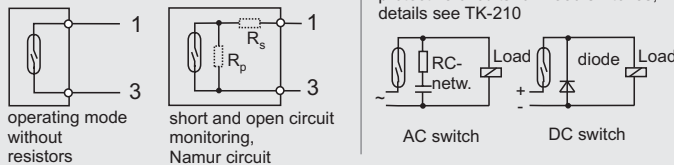

Ordering no.

740.0065XX

	A		
	A		without
	N	A	with Namur circuit
	W	A	with short/open circuit monitoring

Resistor circuit

PHÖNIX

Messtechnik GmbH
Salzschlirfer Straße 13
D-60386 Frankfurt/M.
Tel. +49/69/41 67 42 -20
Fax +49/69/41 67 42 - 29
sales@phoenix-mt.com
www.phoenix-mt.com

PHÖNIX

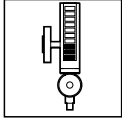

Magnetically controlled Limit Switch

Bistable magnetic switch
Reed contact

Product group **740**

Type **0066**

Sheet: 1/1

Revision: 2

Date:

8/03

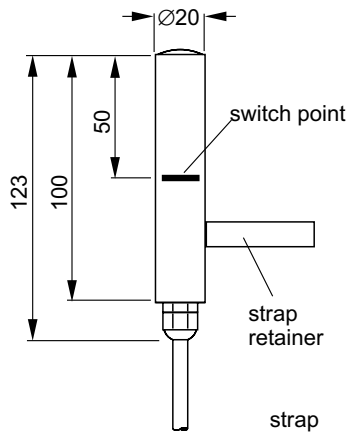

strap retainer
for pipe-Ø
42 - 60 mm

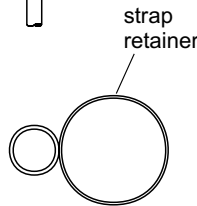

measures in mm

Field of Application

This switch is for signalling level limits with magnetic level gauges type 710.098 and 710.104.

The switch element Reed has a very low mass and so can sustain very high shock and vibration stress.

By using only passive elements (Reed contact, resistors) the switch can operate in hazardous area zone 2 and as part of an intrinsic safe circuit also in zone 1.

General Data

Hysteresis ca. [mm]:	6 mm
Fitting position:	cable gland downwards
Manner of fastening:	with integrated strap retainer
Ingress protection:	IP67
Material housing:	SS
Measures/weight:	123x20/0,31 kg

Design Data

Temperature housing:	-40 ... +120 °C
Contact:	Reed
Function:	SPDT
Switch type:	bistable
Switch cycles:	>10 ⁶
Shock:	15 g
Vibration:	10 g

Electrical Data

Switch voltage:	230 V ~ / 230 V =
Switch current:	1 A ~ / 0,5 A =
max. power limit:	30 VA / 30 W
Connection:	1,5 m silicon cable, 4 x 0,75 mm ²

Connection diagram

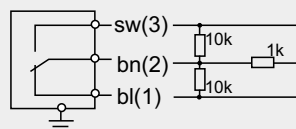
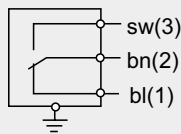

External resistors for operation in circuit acc. to DIN 19234

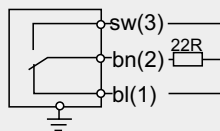

External resistor for operation with SPS

protective circuits for Reed switches

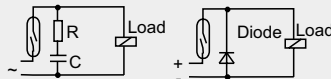

AC circuit

DC circuit

subject to alterations

Ordering no.

7 4 0 . 0 0 6 6

PHÖNIX

Messtechnik GmbH
Salzschlirfer Straße 13
D-60386 Frankfurt/M.
Tel. +49/69/41 67 42 -20
Fax +49/69/41 67 42 - 29
sales@phoenix-mt.com
www.phoenix-mt.com

PHÖNIX

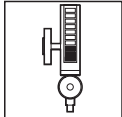

Magnetic Limit switch

Bistable magnetically operated switch
Proximity switch acc. to NAMUR
Switch direction reversible
Switching status remains in the currentless condition

Product group **740**

Type **0200**

Sheet: 1/2

Revision: 9

Date:

1/08



Example: 740.0200AZN MAX

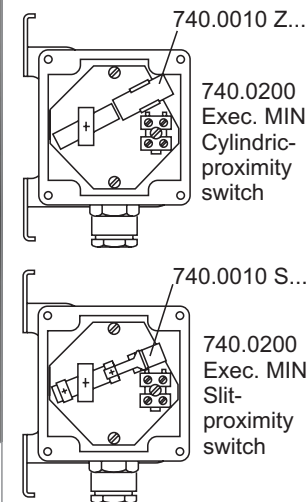

Field of Application

This switch is for signalling level limits with magnetic level gauges. All controllers in accordance with DIN 50227 (NAMUR) may be used for operation. Use in Ex Zone 1 and 2 is allowed only when connected to intrinsically safe circuits. Also redundant and fail safe operation is possible.

General Data

Switching rate: 2 Hz
Hysteresis [mm]:

Gauge Type	ZS	SS	ZN
710.100/102/106/110/120/130	10	5	10
710.098/104	40	25	40
710.104.3/140.3	-	20	-
710.110.3	15	10	10
710.120.3/130.3/150	20	10	10
710.140	10	10	10
710.160	-	15	-

Fastening: with strap retainers (Acc., s. page 2)
Fitting position: Cable gland downwards
Ingress protection: IP67
Material housing: Aluminium
Measures/Weights: 75x80x57/0,4 kg

Design Data

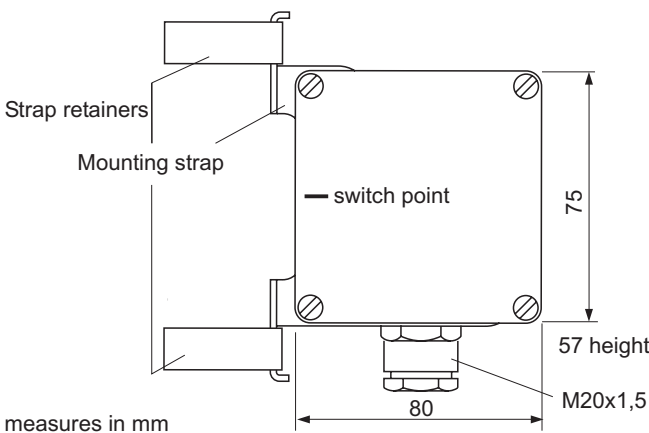
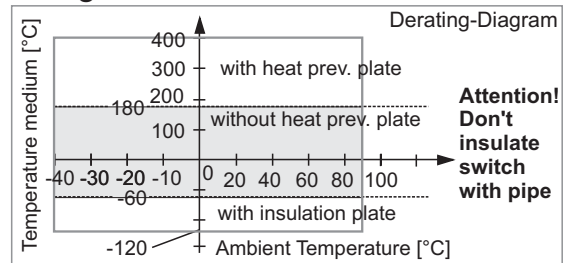

Connection diagram

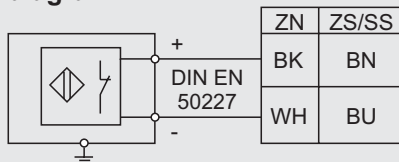

Electrical Data

Interface: to DIN EN 50227
Wire cross section: 2,5 mm²
Cable gland: M20x1,5 blue

Switch module	Type, principle	Redundant safety
740.0010 ZN	Cylindric, Hall	no
740.0010 ZS	Cylindric, inductive	yes
740.0010 SS	Slit, inductive	yes

Subject to alterations

Ordering no.

740.0200AXXX

				normal	Magnetic field float
				I inverted	
			N	Standard	Proximity switch
			S	Redundant	
Safety direction	MIN	L	Z	Cylindric	Form
	MAX	H	S	Slit	

PHÖNIX

Messtechnik GmbH
Salzschlirfer Straße 13
D-60386 Frankfurt/M.
Tel. +49/69/41 67 42 -20
Fax +49/69/41 67 42 -29
sales@phoenix-mt.com
www.phoenix-mt.com



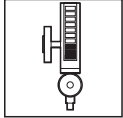

Magnetic limit switch

Application hints

Product group **740**

Type **0200**

Sheet: 2/2

Revision: 9

Date:

1/08

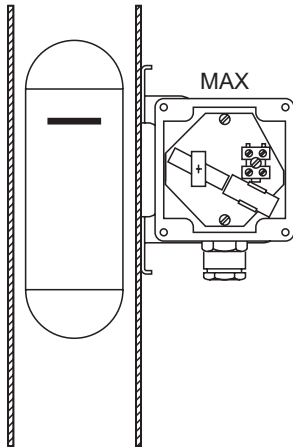

740.0200 MAX for H-level
The magnet damps the proximity switch when the float is higher (fail-safe).

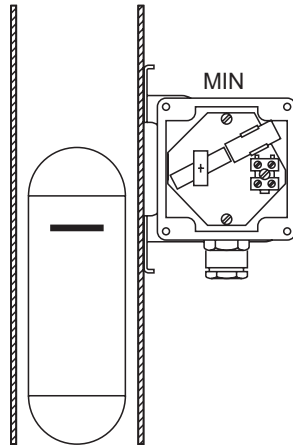

740.0200 MIN for L-level
The magnet damps the proximity switch when the float is lower (fail-safe).

Power supply (DIN EN 50227): 8,2 V= (Ri ca 1kΩ)
Wire resistance: < 100R

Switch module Type 740.0010 ZN

Exi Data:

Parameter	EEx ib IIC T6/T5/T4
U _i	≤ 18 V
I _i	≤ 86 mA
P _i	≤ 95 mW
L _i	1 μH
C _i	230 nF

OFF-current: < 0,4 mA
ON-current: > 2,50 mA
Remaining ripple: < 0,03 mA

Switch module Type 740.0010 ZS/SS

Ex-Data: II 2G EEx ia IIC T6/T5/T4
U_i: ≤ 16 V
L_i ZS/SS: 150/100 μH
C_i ZS/SS: 50/30 nF
Temperature classes ZS + SS:

P _i [mW]	34	64	169	242
I _i [mA]	25	25	52	76
T6 [°C]	73	66	45	30
T5 [°C]	88	81	60	45
T4 [°C]	100	100	89	74

OFF-current: ≤ 1 mA
ON-current: ≥ 3mA

Power supply and signal conversion acc. to NAMUR

Example for discrete switch circuit

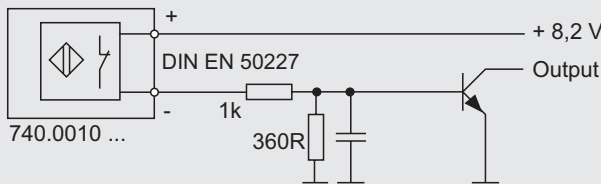

Operation with an intrinsically safe controller

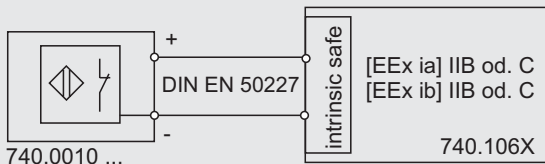

Certificates

Switch module Type 740.0010 ZN

EC-Type-Examination Certificate: ZELM 02 ATEX 0083

Switch module Type 740.0010 ZS/SS

EC-Type-Examination Certificate: PTB 00 ATEX 2049 X

May be connected to intrinsic safe circuits and may be operated in zone 1 and zone 2.

Subject to alterations

Ordering no. Accessories

fixing elements

Strap retainers for 710.104/2XX	171538
Strap retainers for 710.100/103	171546
Strap retainers for 710.110/120/106/130/100.3	171553

PHÖNIX

Messtechnik GmbH
Salzschlirfer Straße 13
D-60386 Frankfurt/M.
Tel. +49/69/41 67 42 -20
Fax +49/69/41 67 42 -29
sales@phoenix-mt.com
www.phoenix-mt.com

PHÖNIX